

TRUECUT 201

Spare Parts list



Date 08/20/15

MAIN HOUSING ASSEMBLY

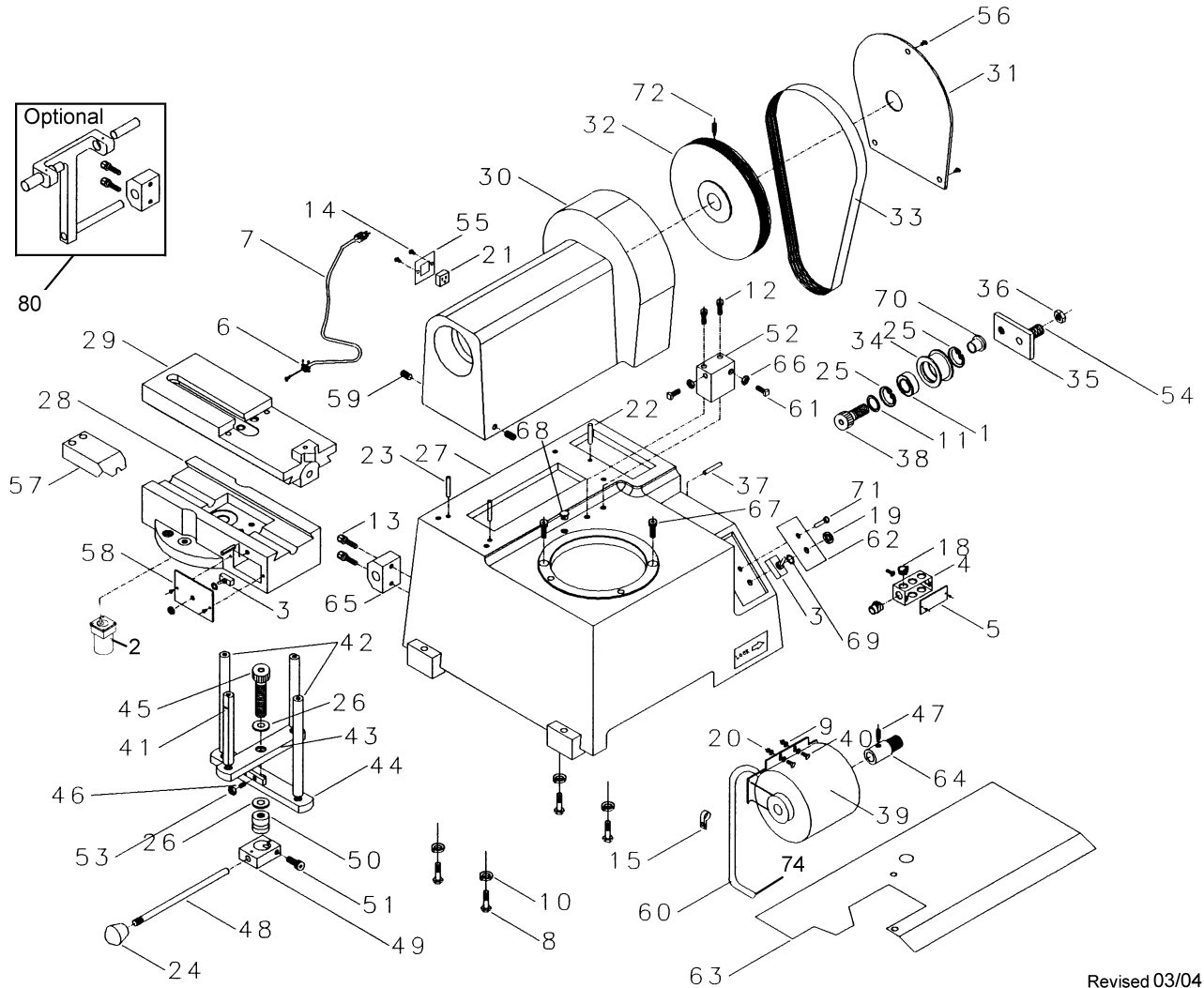

Revised 03/04

NO.	P/N	DESCRIPTION	NO.	P/N	DESCRIPTION
1	CL20	BEARING	21	CL619-1	RECEPTACLE
2	CL830A CL830 CL831	Gear motor assembly consists of MOTOR, W/Capacitor GEARBOX	22	CL638	DOWEL 5/16X3/4
3	CL101-1	SWITCH	23	CL639	DOWEL 5/16 X 1 1/2
4	CL103-1	ELECTRICAL BOX	24	CL688	KNOB
5	CL104-1	ELECTRICAL BOX COVER	25	CL689	RETAINING RING
6	CL539	CONNECTOR	26	CL695	1/2 SAE FLAT WASHER
7	CL118	POWER CORD	27	CL708	BASE
8	CL139	HHCS 3/8-16 X 1 1/4	28	CL709	CARRIAGE
9	CL180	LOCKWASHER 5/16	29	CL710	CROSS SLIDE
10	CL181	LOCKWASHER 3/8	30	CL711	SPINDLE HOUSING
11	CL182	SPRING WASHER	31	CL712	BELT COVER
12	CL770	SHCS 1/4-20 X 2	32	CL713	SPINDLE PULLEY
13	CL223-1	SHCS 1/4-20 X 3/4	33	CL714	BELT
14	CL225	BHSHCS 10/24X1/4	34	CL715	IDLER PULLEY
15	CL250-1	P-CLIP	35	CL716	IDLER PULLEY BRACKET
18	CL548	CONNECTOR	36	CL717	LOCK NUT
19	CL670	TOGGLE BOOT	37	CL718	STOP PIN
20	CL597	ACORN NUT 5/16-18	38	CL691	STRIPPER BOLT 1/2 X 3/4
			39	4314	1/2 HP DRIVE MOTOR (CL720)
			40	CL94	CARRIAGE BOLT 5/16-18 X 1

NO.	P/N	DESCRIPTION
41	CL722	SUPPORT BAR 6"
42	CL723	SUPPORT BAR 6 5/8"
43	CL724	CLAMPING BAR 6"
44	CL725	CLAMPING BAR 7 1/2*
45	CL726	SHCS 1/2-13
46	CL727	HALF DOG
47	CL728	HALF DOG 5/16-18
48	CL729	LOCKING LEVER
49	CL730	LOCKING LEVER BRACKET
50	CL731	CLAMPING NUT
51	CL732	CLAMPING BOLT
52	CL734	CARR. ALIGNMENT BLOCK
53	CL17	JAM NUT 1/4
54	CL736	SSS 5/8-11 X 1 3/8
55	CL737	OUTLET PLATE
56	CL767	BHSHCS 6/32 X 1/4
57	CL743	GEAR COVER
58	CL744	SWITCH PLATE
59	CL735	SSS 3/8-16 X 5/8
60	CL541	MOTOR CORD
61	CL170	SQHSS 5/16-18 X 7/8
62	CL772	SWITCH MOUNTING PLATE
63	CL774	BOTTOM GUARD PLATE
64	CL778	MOTOR PULLEY
65	CL785	STABILIZER MTG. BRACKET
66	CL98	JAM NUT 5/16
67	CL739	SHCS 5/16-18 X 1
68	CL637	PLUG
69	CL107	SHAKE PROOF WASHER
70	CL682	BUSHING
71	CL662	INDICATOR LIGHT
72	CL192	SSS 1/4-20 X 1/4
73	CL813	M5 .8 x 20 SHCS
74	CL106	Anti Short
80	CL503B	Rotor Stabilizer Kit – stabilizer, block, hardware

DISC TOOL PLATE ASSEMBLY

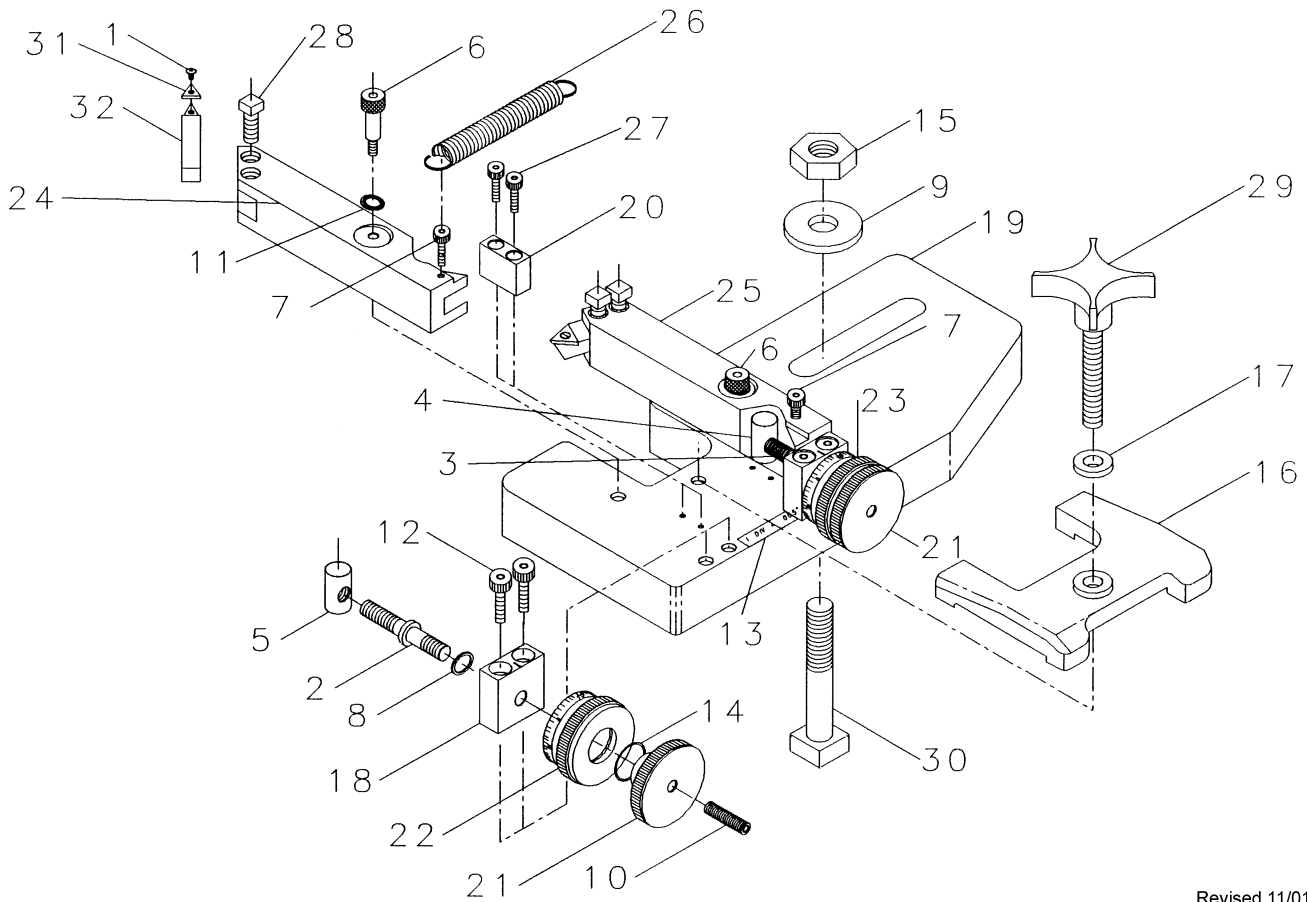

Revised 11/01

NO.	P/N	DESCRIPTION	NO.	P/N	DESCRIPTION
1	CL39	TOOLBIT SCREW	17	CL596	WASHER
2	CL56-1	Positioning Screw (L) 2 1/4" long RHT	18	CL604	SUPPORT BLOCK
3	CL57-1	Positioning Screw (R) 2 1/4" long LHT	19	CL605	TOOL PLATE
4	CL70	TOOL ADJUSTING NUT (R) LHT	20	CL606	ALIGNING BLOCK
5	CL71	TOOL ADJUSTING NUT (L) RHT	21	CL607	TOOL POSITIONING KNOB
6	CL75-1	STRIPPER BOLT 5/16 X 1	22	CL608	INDICATOR DIAL (L)
7	CL77	SHCS 10/32 X 1/2	23	CL609	INDICATOR DIAL (R)
8	CL142	SPRING WASHER	24	CL610	TOOL HOLDER (L)
9	CL156	WASHER	25	CL611	TOOL HOLDER (R)
10	CL191	SSS 5/16-24 X 3/4	26	CL612	SPRING
11	CL211	SPRING WASHER	27	CL623	SHCS 8/32 X 7/8"
12	CL223	SHCS 1/4-20 X 1 1/4	28	CL624	SQ.HD.SS 5/16-18 X 1/2
13	CL245-1	DIVISION LABEL	29	CL625	LOCKING SCREW & KNOB
14	CL254	"O" RING	30	CL776	BOLT
15	CL527	TOOL PLATE LOCKING NUT	31	W139	TOOLBIT Package of 10
16	CL575	TOOL HOLDER CLAMP	32	W140	TOOL BIT HOLDER (DISC) With 1 tool bit

DRUM TOOL PLATE

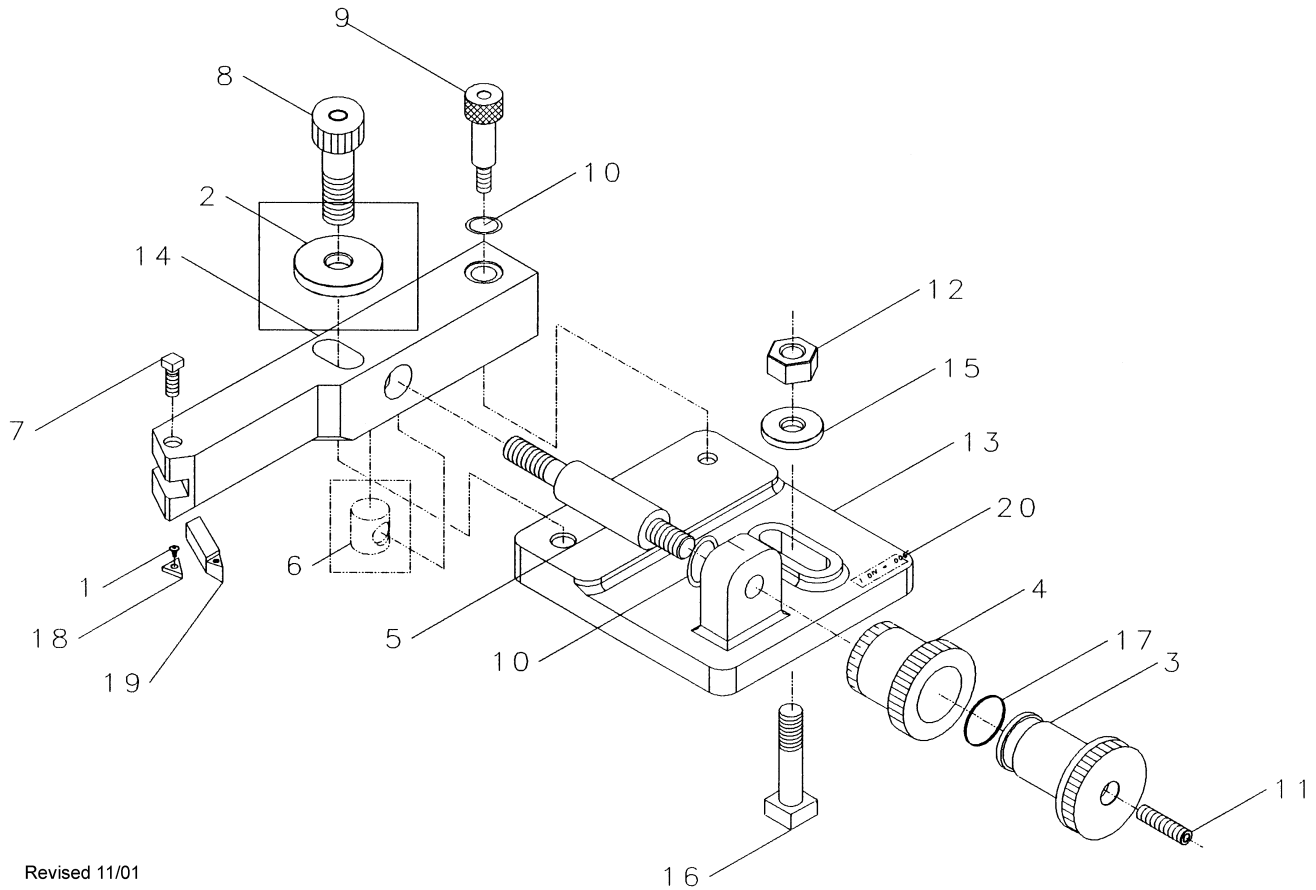

Revised 11/01

NO.	P/N	DESCRIPTION	NO.	P/N	DESCRIPTION
1	CL39	TOOLBIT SCREW	11	CL209	SSS 3/8-16 X 1
2	CL156	WASHER	12	CL527	TOOLPLATE LOCKING NUT
3	CL158-1	ADJUSTING KNOB	13	CL771	TOOLPLATE
4	CL158-2	INDICATOR DIAL	14	CL773	BORING BAR
5	CL161	ADJUSTING SCREW	15	CL775	TOOLPLATE WASHER
6	CL162	ADJUSTING NUT	16	CL776	"T" BOLT
7	CL170	SQ.HD.SS 5/16-18 X 3/4	17	CL783	"O" RING
8	CL173	CLAMPING BOLT	18	W139	TOOLBIT Package of 10
9	CL174-1	STRIPPER BOLT 1/2 X 1 1/2	19	W140-1	TOOLBIT HOLDER
10	CL182	SPRING WASHER	20	CL245	DIVISION LABEL

CARRIAGE ASSEMBLY

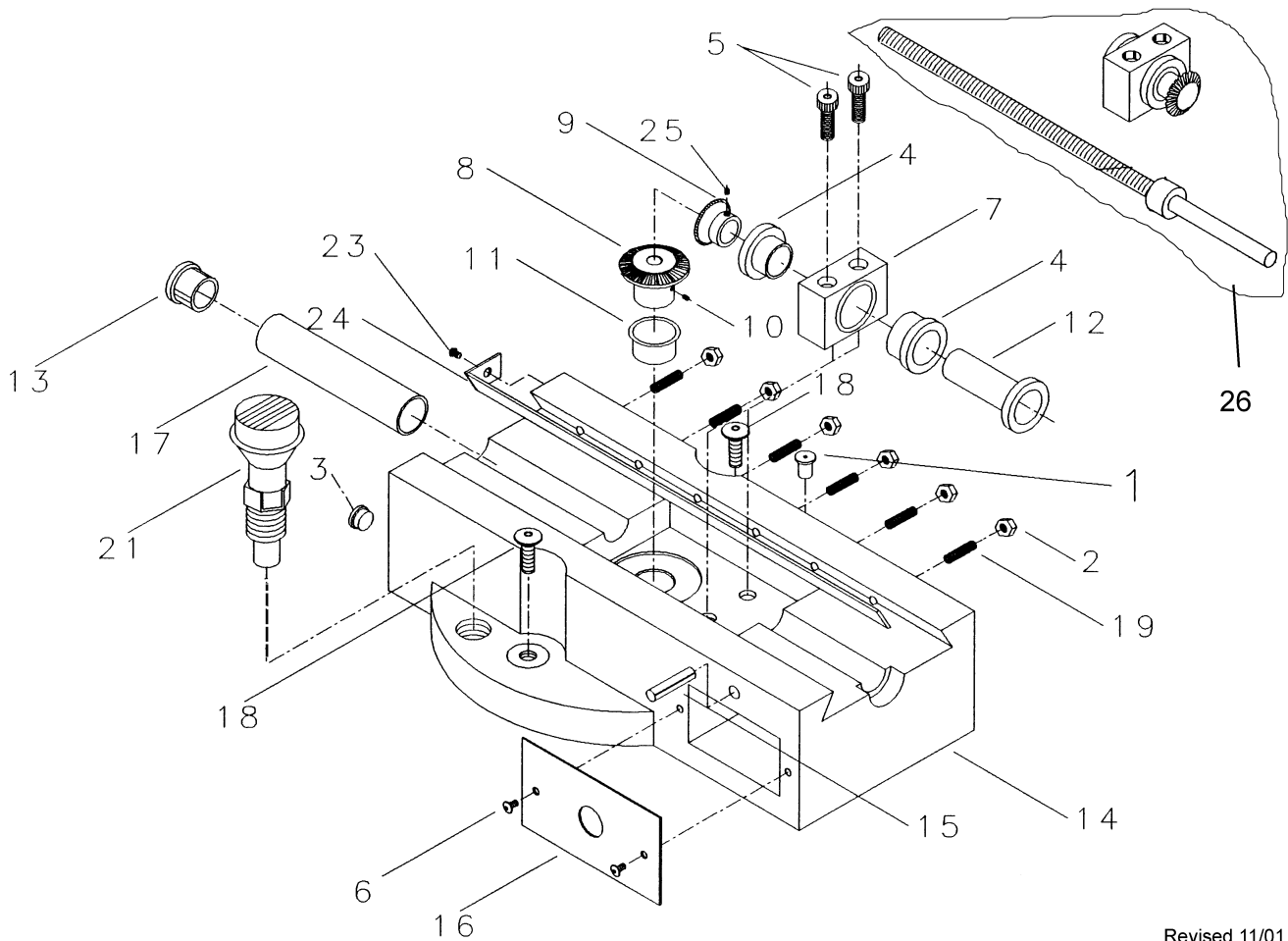

Revised 11/01

NO.	P/N	DESCRIPTION	NO.	P/N	DESCRIPTION
1	CL15-1	OILER	12	CL585	CROSS SLIDE SLEEVE
2	CL17	JAM NUT 1/4-20	13	CL659	TUBE PLUG
3	CL73	RUBBER PLUG	14	CL709	CARRIAGE
4	CL159-1A	BUSHING (2)	15	CL718	STOP PIN
5	CL223	SHCS 1/4-20 X 1 1/4	16	CL744	SWITCH COVER PLATE
6	CL225	BHSHCS 1/4-20 X 1/4	17	CL742	LEADSCREW TUBE
7	CL516	BLOCK	18	CL745	BHSHCS 5/16-18 X 1 1/2
8	CL812	GEAR	19	CL748	GIB SCREW
9	CL519-1	GEAR	21	CL782-1	LOCKING PIN
10	CL524	SSS 1/4-28 X 1/4	23	CL741	BHSHCS 10-24 X 3/8
11	CL571	BUSHING	24	CL746	GIB
			25	CL758	SSS 10/32 X 1/4

26 CL516C Gear Block assembly – gear block & lead screw

SPINDLE SHAFT ASSEMBLY

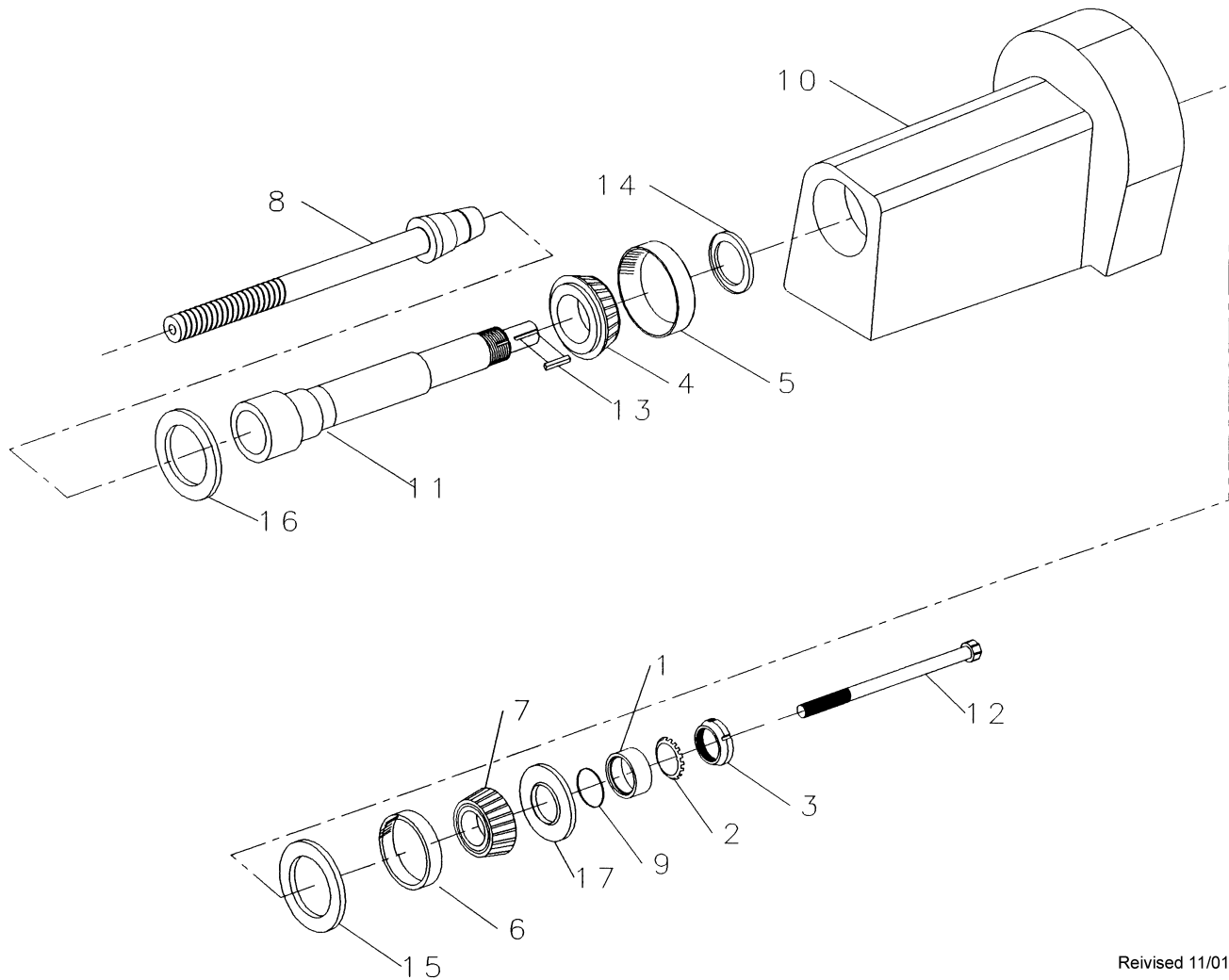

Revised 11/01

NO.	P/N	DESCRIPTION	NO.	P/N	DESCRIPTION
1	CL30-1	SEAL SPACER	10	CL711	SPINDLE HEAD
2	CL35	LOCK WASHER	11	CL754	SPINDLE SHAFT
3	CL36	LOCKNUT	12	CL756	DRAW BOLT
4	CL261	BEARING CONE	13	CL757	KEY
5	CL262	BEARING CUP	14	CL759	SEAL
6	BDL276-1	BEARING CUP	15	CL760	SEAL
7	BDL276-2	BEARING CONE	16	CL779	SEAL
8	CL538	1" ARBOR STANDARD 10.5" LONG	17	CL780	SEAL
9	CL636	"O" RING			

CROSS SLIDE CARRIAGE

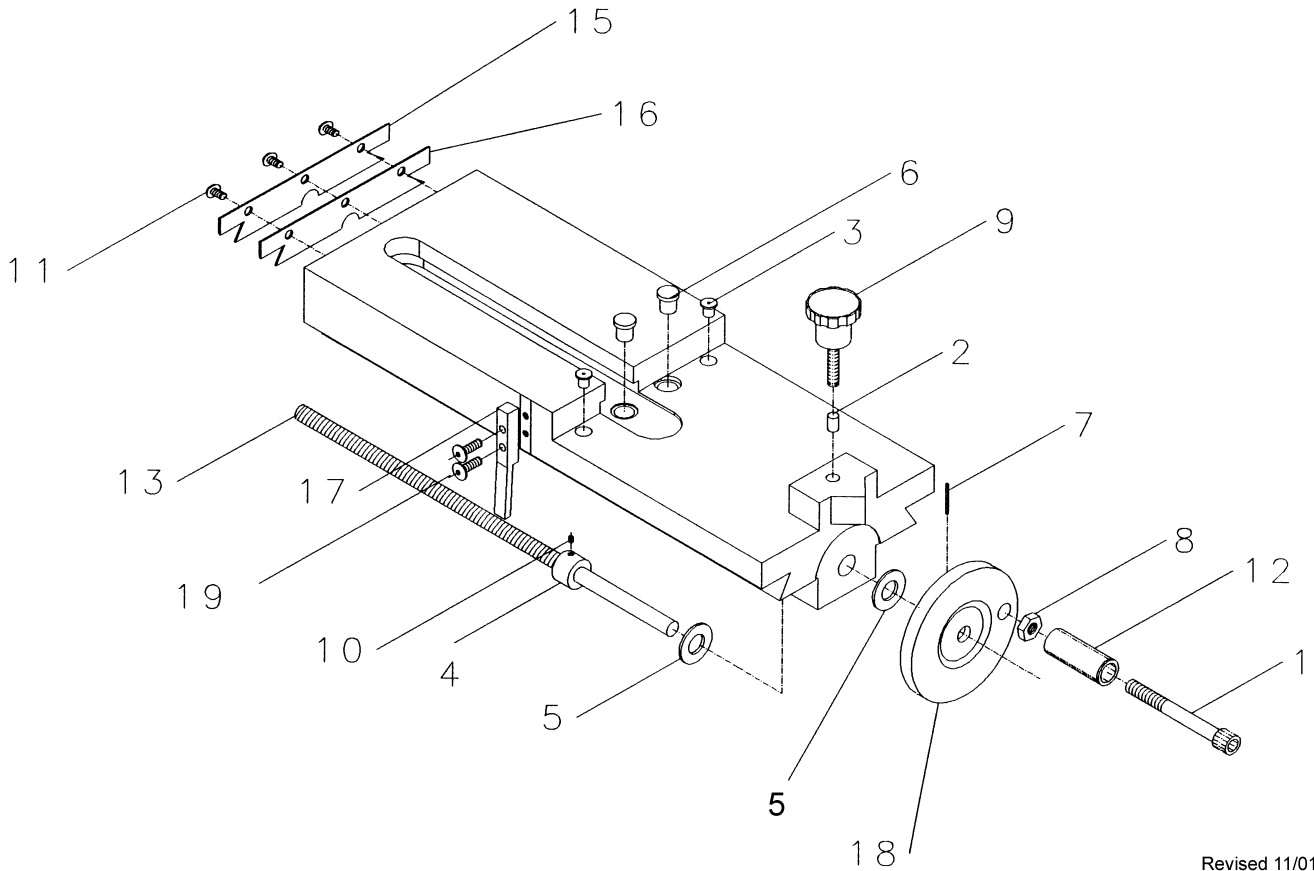

Revised 11/01

NO.	P/N	DESCRIPTION	NO.	P/N	DESCRIPTION
1	CL11-1	HANDLE BOLT	10	CL192	SSS 1/4-20 X 1/4
2	CL012	BRASS PLUG	11	CL225	BSHS 1/4-20 X 1/4
3	CL15-1	OILER	12	CL265-2	SWIVEL HANDLE
4	CL59	COLLAR	13	CL516C	LEAD SCREW (11 3/4" LONG)
5	CL67-1	THRUST WASHER	15	CL749	WIPER RETAINER
6	CL73	RUBBER PLUG	16	CL750	WIPER
7	CL81	SPRING PIN 1/8 X 1	17	CL751	SHUT-OFF ARM
8	CL98	JAM NUT 5/16 - 18	18	CL753	HANDWHEEL SPACER
9	CL141-1	LOCKING KNOB ASSY.	19	CL784	BSHS 1/4-20 X 7/8

#13 Lead Screw – Only available as a kit which consist of the gear block & lead screw, see Carriage Assembly page